



# G4K BLACKBOX

## How to Connect & Configure a Multi Frequency 3.5G Wireless Modem with the G4K BLACKBOX



## Contents

I.	Overview.....	3
II.	Parts & Accessories .....	4
III.	Connecting the Modem.....	4
III.1	SIM Card Insertion.....	4
III.2	Modem Cable Connections .....	5
III.3	Modem to POE Connection.....	5
III.4	POE, Modem to G4K BLACKBOX Connection .....	5
IV.	Modem Configuration .....	6

## I. Overview

The G4K BLACKBOX device series now features advanced wireless connectivity via a Multi Frequency 3.5G Wireless Modem. In addition, with a standard Power over Ethernet (POE) adapter, the device is able to verify wireless connectivity automatically, by switching the modem off & on, thereby restarting it. The purpose of this document is to describe how to connect and configure the Multi Frequency 3.5G Wireless Modem with the BLACKBOX G4K devices.

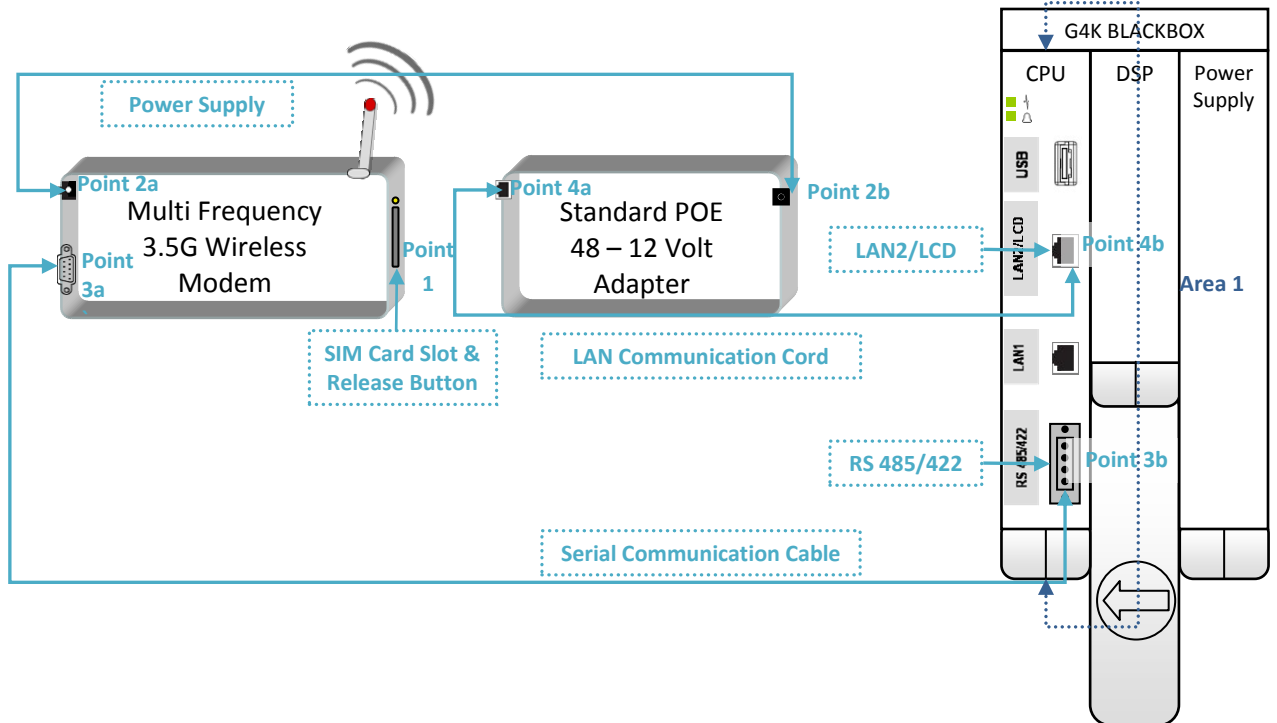

Diagram I: 3G/GPRS Wireless Connection to the G4K BLACKBOX

## II. Parts & Accessories

Description	Ordering Information (Part Number)	Illustration
Multi Frequency 3.5G Wireless Modem	SCM-0001-0000	
Serial Communication Cable	(Included with the modem)	
Power Supply	EPC-2012-2190 (EU) EPC-7012-2190 (USA)	
LAN Communication Cord	TOE-0010-0013	
Standard POE 48 – 12 Volts Adapter (Purchased Independently)	EBO-5050-0000	

## III. Connecting the Modem

It is recommended that you purchase a standard POE 48-12 Volts adapter (not supplied with the modem & accessories), as it will enhance your wireless connectivity with the automated communication verification feature. Connecting the Modem to the G4K BLACKBOX:

### III.1 SIM Card Insertion

- Insert your SIM Card by pushing the indicated yellow button (*Diagram I: Point 1*)
- Close the housing slot



Figure I: SIM card Position Modem

### III.2 Modem Cable Connections

- Plug the power supply into the power supply port (*Diagram I: Point 2a*)
- Plug the serial communication cable into the communication port (*Diagram I: Point 3a*)



Figure II.1: Modem Power Supply Port



Figure II.2: Modem Communication Port

### III.3 Modem to POE Connection

- Connect the POE to the modem by plugging the power supply into the DC out port (*Diagram I: Point 2b*)



Figure III.1: DC Out Port POE



Figure III.2: Modem Connected to POE

### III.4 POE, Modem to G4K BLACKBOX Connection

- All the cable connections for the G4K BLACKBOX is situated on the Central Processing Unit (CPU) (*Diagram I: Area 1*)
- Connect the POE to the BLACKBOX by plugging in the LAN communication cable into the P+DATA IN port (*Diagram I: Point 4a*)
- Plug in the LAN communication cable into LAN 2/LCD port (*Diagram I: Point 4b*)
- Plug the serial communication cable into the RS 485/422 port (*Diagram I: Point 3b*)



Figure IV.1: P+Data IN Port  
POE Adapter



Figure IV.2: POE  
Connected to  
BLACKBOX



Figure IV.3:  
Modem Connected  
to BLACKBOX



Figure IV.4: POE,  
Modem Connected  
to BLACKBOX

## IV. Modem Configuration

Configuration takes place via the Web Interface of the G4K BLACKBOX. The configuration process will verify:

- POE, Modem to G4K BLACKBOX connection
- Serial port settings

To initiate configuration:

- Open the Web Interface
- Open the **“Configuration”** tab
- Select the **“Serial Ports”** option

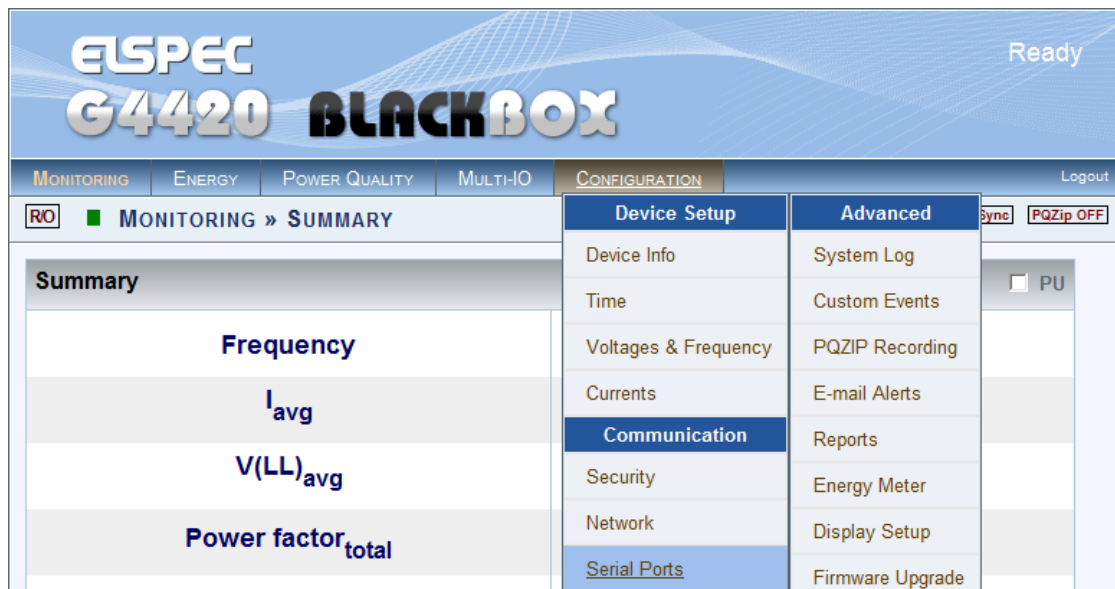

Figure V: Web Interface – Serial Ports

**Note:** Only a proportion of the serial port settings are dependent on the ISP Service Provider. Include the parameters according to the appropriate provider’s parameters in the following textbox fields:

- RS-485 / RS-422 Section: **“Bitrate” & “Serial Mode” \***
- PPP Configuration Section: **“User Name” & “Password”**
- Modem Configuration: **“Init String” \***, **“Reset String”\***, **“Default Init”\*** & **“Phone Number”** (Inserted SIM Card Cell #)  
\* (Standard Inclusion – Remains Unchanged)

The available configuration parameters are:

Configuration	Standard ISP Service Provider Modem Configuration	ISP Service Provider- Example Modem Configuration
Bitrate	115,200	115,200
Serial Mode	PPP	PPP
User Name	(Individual ISP Service Provider)	Cellcom
Password	(Individual ISP Service Provider's Password)	HyD43f
Init String	at+cgdcont=1"ip", "APN"	at+cgdcont=1,"ip", "internetg"
Reset String	ATZ	ATZ
Default Init	AT+IFC=0,0	AT+IFC=0,0
Phone Number	Inserted SIM Card Cell #	Inserted SIM Card Cell #

\* (Standard Inclusion – Remains Unchanged)

- Select the **“Apply Changes”** command

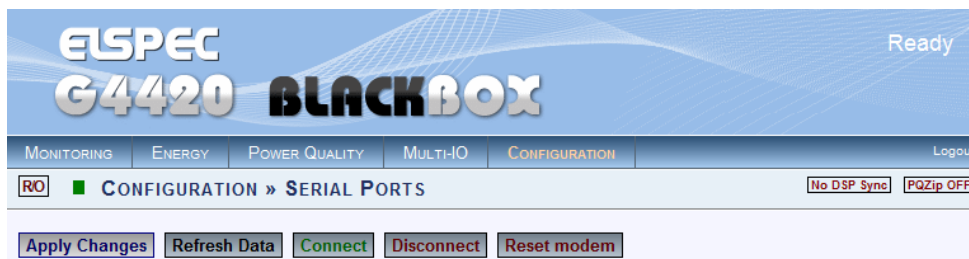

Figure VI: Apply Changes Command – Web Interface

- Configuration is now completed

Completed examples of ISP Service Provider's modem configuration in the Web Interface:

The screenshot displays the Elspec G4420 BlackBox web interface. At the top, the status is 'Ready'. The navigation menu includes MONITORING, ENERGY, POWER QUALITY, MULTI-IO, and CONFIGURATION. The current page is 'CONFIGURATION » SERIAL PORTS'. There are status indicators for 'No DSP Sync' and 'PQZip OFF'. Action buttons include 'Apply Changes', 'Refresh Data', 'Connect', 'Disconnect', and 'Reset modem'.

**RS-485 / RS-422**

Bitrate	Data Bits	Parity	Stop Bits	Flow
115200	8 bit	None	1	Full
Serial Mode			ModBus Slave Address	
PPP			159	

**PPP Status**  [Message Log]

PPP IP	PPP Subnet	Signal Quality
N/A	N/A	-----

**Message Log**

Empty

**PPP Configuration**

PAP Status	CHAP Status	Username	Password
Enable	Enable	Service Provider	Provider P.word

**Modem Configuration**

Init String	at+cgdcont=1,,"ip","APN"	Reset String	ATZ
Default Init	AT+IFC=0,0	Phone Number	Inserted SIM Card Cell #

Figure VII: Modem Configuration  
Standard ISP Service Provider Settings – Web Interface

**ELSPEC**  
**G4420 BLACKBOX**
Ready

---

MONITORING ENERGY POWER QUALITY MULTI-IO CONFIGURATION
Logout

---

RO ■ CONFIGURATION » SERIAL PORTS
No DSP Sync PQZip OFF

---

Apply Changes
Refresh Data
Connect
Disconnect
Reset modem

---

**RS-485 / RS-422**

Bitrate	Data Bits	Parity	Stop Bits	Flow
115200 ▾	8 bit	None	1	Full ▾
Serial Mode			ModBus Slave Address	
PPP ▾			159 ↕	

---

**PPP Status**  [Message Log]

PPP IP	PPP Subnet	Signal Quality
N/A	N/A	-----

**Message Log**

Empty

---

**PPP Configuration**

PAP Status	CHAP Status	Username	Password
Enable ▾	Enable ▾	Cellcom	HyD43f

---

**Modem Configuration**

Init String	at+cgdcont=1,"ip","internetg"	Reset String	ATZ
Default Init	AT+IFC=0,0	Phone Number	Inserted SIM Card Cell #

*Figure VIII: Modem Configuration  
ISP Service Provider, Example – Web Interface*